

1 2 3 4 5 6

A

A

B

B

C

C

D

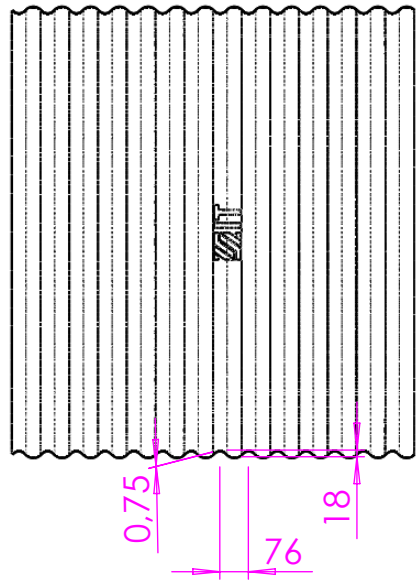
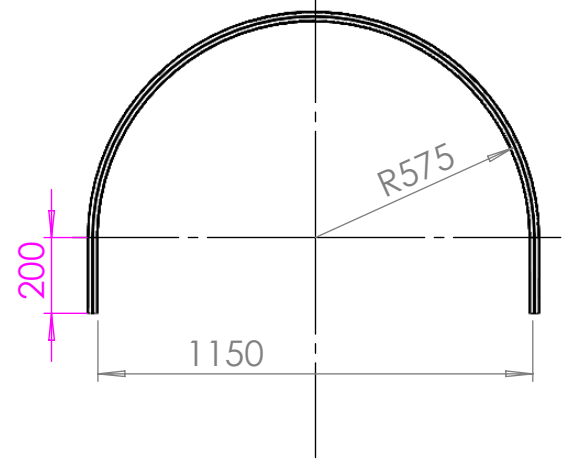
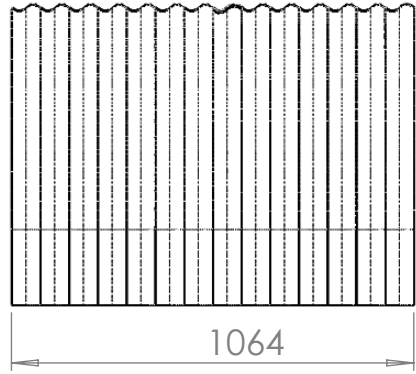
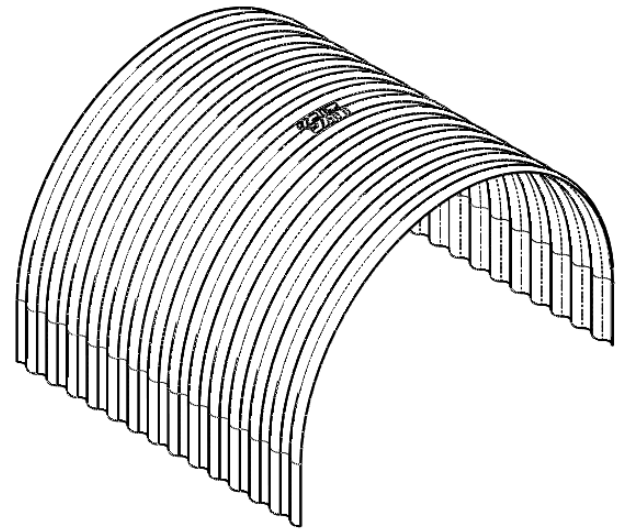

Stahl, verzinkt

All screw connections must be checked for tightness before commissioning. If necessary, the screw connections must be tightened accordingly. Attachment points/brackets may need to be reinforced locally at the customer facility, to ensure sufficient rigidity.

Alle Angaben in mm Zeichnungen nicht maßstabsgerecht  
Irrtümer und technische Änderungen vorbehalten!  
All dimensions in mm, Drawings not true to scale  
Errors and technical changes reserved!

IT Schutzvermerk beachten Protection Notice acc to		ISO 16016		Allgemeintoleranzen ISO 2768 -m		Werkstückkanten DIN ISO 13715	
				Datum	Name		
-	---	--_--_---	-_---	Erstellt:	19.08.2020	I.T.	
-	---	--_--_---	-_---	Geprüft:	19.04.2023	I.T.	
-	---	--_--_---	-_---	Benennung:			
-	---	--_--_---	-_---	Abdeckhaube			
-	---	--_--_---	-_---	Gewicht: 1.0037 (S235JR)			
Revision	Änderung	Datum	Name				



**InduTechnik**  
your solution, your advance

Zeichnungsnummer:  
**GF.10.0800.31**

A4  
DE

IT alle Rechte vorbehalten / IT all rights reserved